

JP-2300-MK MOUNTING ARM KIT

MOUNTING ARM AND HEATER BRACKET

MODELS: 2100 / IO-100; 2300 / IO-210

ALLOWS MOUNTING OF HEATER:

- 27.5" FROM MOUNTING SURFACE
- EITHER HORIZONTAL
- OR AT 30° ANGLE (MAXIMUM)

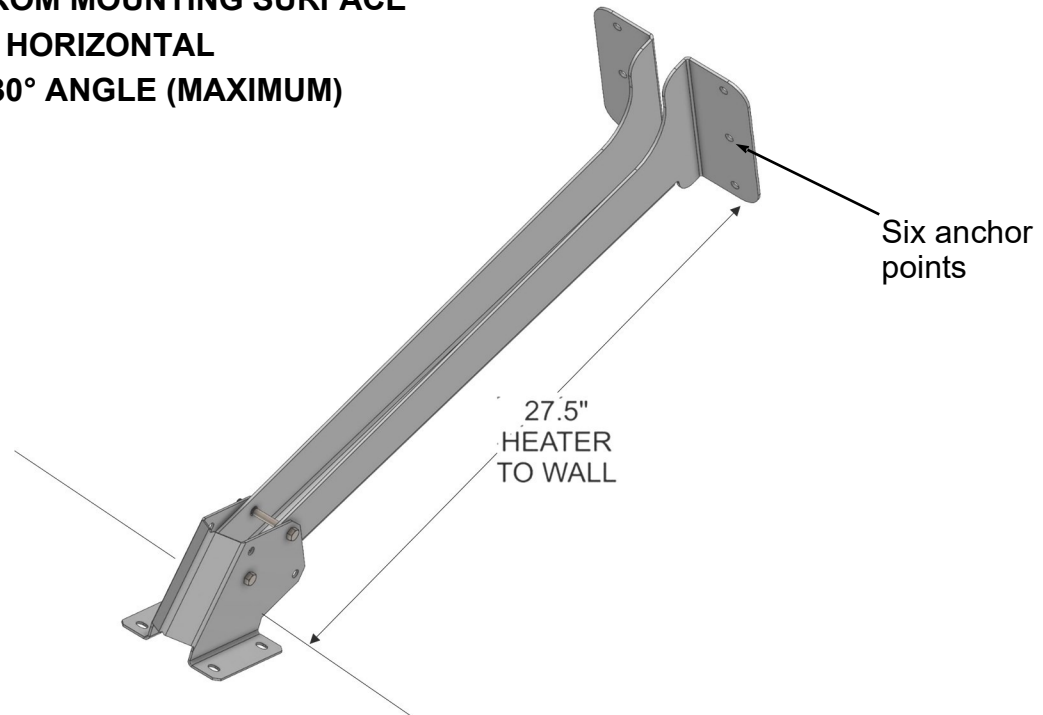

HEATER BRACKET FASTENS TO MOUNTING ARM
WITH 2 EACH NUTS & BOLTS SUPPLIED

WARNING: Ensure that anchoring to the structure (field supplied anchor hardware) is of sufficient strength, integrity and workmanship, to adequately support the weight of the heater and any other potential loads such as snow build up and wind.



- See next page for assembly of heater bracket to mounting arm for desired heater orientation at horizontal or 30° angle
- Mounting arm dimensions on page 3

NOTE: MOUNT HEATER AT MAXIMUM 30° ANGLE

Using pairs of holes in the **heater bracket** allows heater orientation:

- Horizontal
- Angled at 30° (MAXIMUM angle mount)

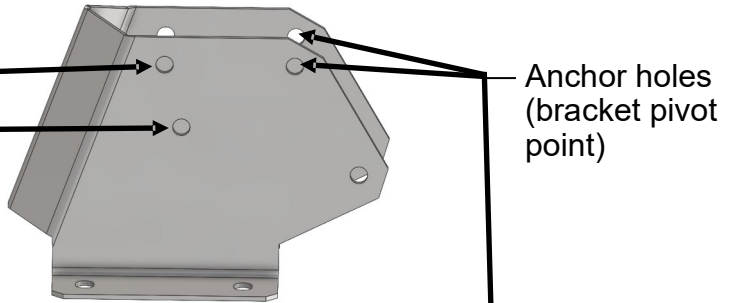

Assemble Mounting Bracket to Mounting Arm using bolts and nuts supplied:

- Align the anchor holes in the heater bracket and the mounting arm, and insert a bolt
- Finger tighten nut on to bolt to allow rotation of the heater bracket
- Align the desired mounting angle holes in the heater bracket to the outermost holes in the mounting arm
- Insert second bolt and finger tighten ONLY nut to bolt
- Horizontal mount
- 30° Angle mount

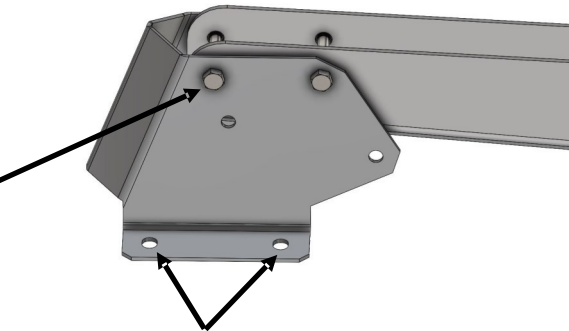
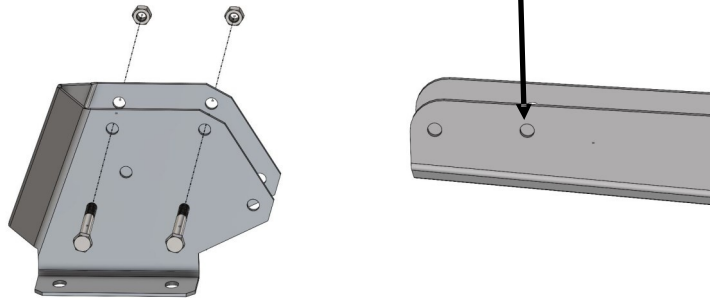

Studs at top of heater to mounting bracket

IMPORTANT

- **Install heater to mounting bracket** (4 studs / nuts) **BEFORE** tightening nuts on bolts to mounting arm with wrench

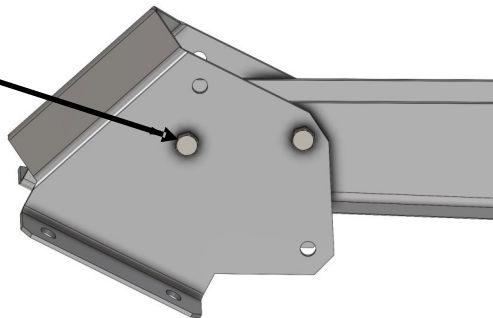

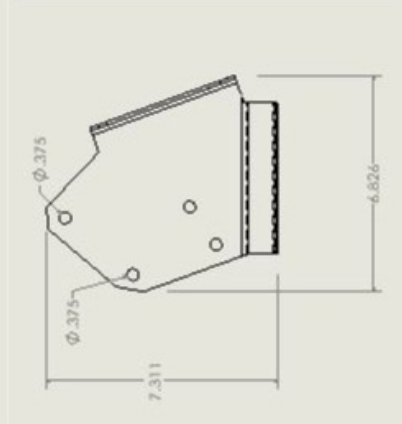
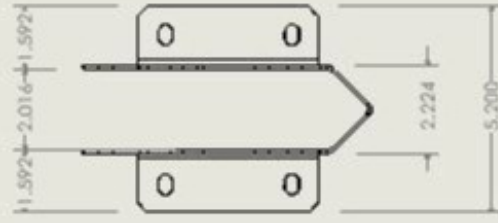
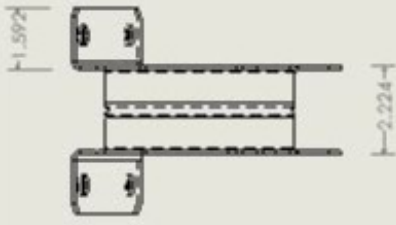
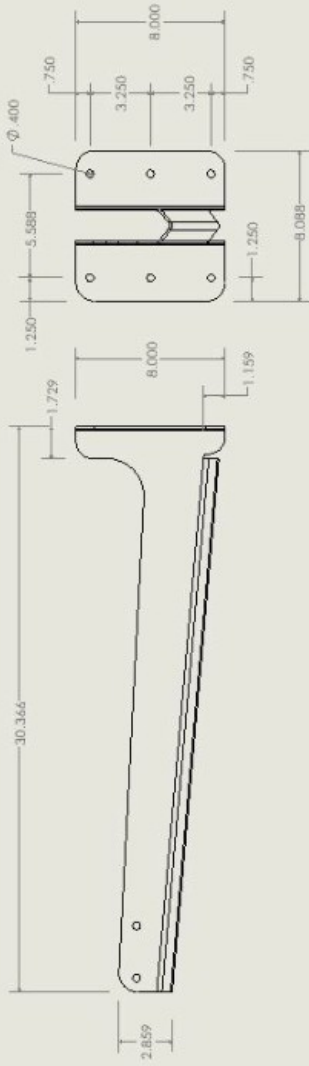

Mounting Arm Kit Assembly
weighs 13.35 lb

JP-2300-MK

MOUNTING ARM AND HEATER
BRACKET KIT

MODELS: 2100 / IO-100; 2300 / IO-210

Drawing Name:

Material:

Thickness: 0.135

Current Revision #

1	4
2	5
3	6

Source of Drawing Information:

Sch Part# JP-2300-MK
Sch Part# JP-2300-MK-SS